

MCCES1 Specifications



APPLICATION: the Moore CCES1 is a configurable, outdoor environment communication enclosure designed and manufactured for applications such as Telephony, CATV and Wireless. The CCES1 provides significant protection against vandalism and the effects of weather, such as wind-driven rain, sleet, snow and corrosion.

STANDARDS:

Type 3R, 4X

CONSTRUCTION:

A. ENCLOSURE

- 1 The complete enclosure is constructed of .125" 5052 H-32 aluminum providing strong construction and corrosion protection.
- 2 The enclosure's main equipment bay is equipped with two (2) 19"/23" rack frame assemblies, one (1) fixed and one (1) which swings 90°. Total rack space is 84.5" (48RU)[Max (50RU) - two (2) fixed racks].
- 3 All door openings are flanged to provide a secure seal, protect against vandalism, and allow water to drain away from openings.
- 4 All exterior seams are sealed weather-tight with silicone sealant
- 5 AC Distribution Compartment houses AC electrical components and air conditioning system. It is designed to meet the standards of NEMA 3R.
- 6 Fiber Storage Compartment provides space to store and splice cable. It is designed to meet the standards of NEMA 3R. Floor panel is removable.
- 7 Main Equipment Bay has front and rear access, is completely insulated and climate-controlled.

B. DOORS

- 1 Main Equipment Bay and doors are equipped with heavy-duty three point latching mechanisms with flush handles and ability to be both special key and pad locked.
- 2 AC Distribution Compartment door is provided with screened louvers.
- 3 All doors and access panels are sealed with closed-cell neoprene gasket
- 4 A continuous hinge is provided on all hinged doors.

C. BATTERY DRAWER

- 1 The Battery Drawer is completely ventilated and designed to house up to six (6) batteries.
- 2 Heavy-duty slides support up to 600 lbs. per pair.

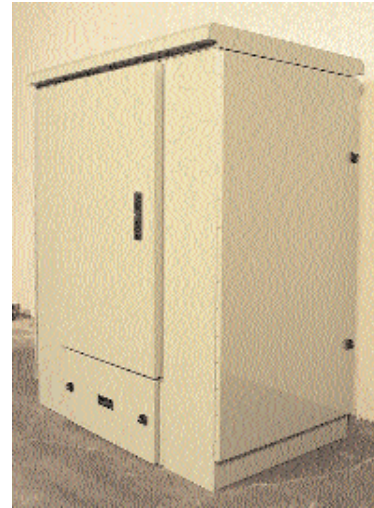

D. AC DISTRIBUTION

- 1 All electrical components are installed, wired and tested.
- 2 AC system includes 100-amp load center with 60-amp main breaker, one (1) 220 VAC equipment outlet in main bay & two (2) 110 VAC GFCI convenience receptacles.
- 3 Generator transfer switch with 60-amp inlet connector including mating generator plug.
- 4 Door-activated overhead lighting.

E. CLIMATE CONTROL

- 1 Installed, wired and tested air conditioner system is 2,000 - 12,000 BTU, thermostat-controlled, and closed-looped.
- 2 Thermostat-controlled space heating system is provided in Main Equipment Bay.
- 3 Battery Drawer is wired with tray heating pads installed under stainless steel battery trays provided.

F. ENCLOSURE FINISH

- 1 The CCES1 enclosure system is treated in a pre-paint process, powder-coated and dried by radiant heat. The standard finish coat is polyester powder. Standard colors are Bellcore Beige or Telecom Green.

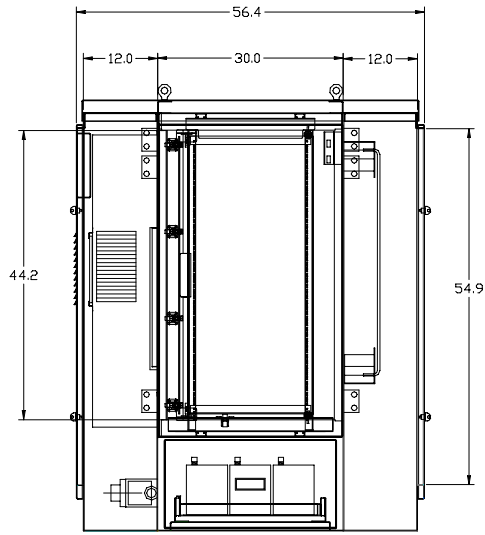

MCCES1 Front View

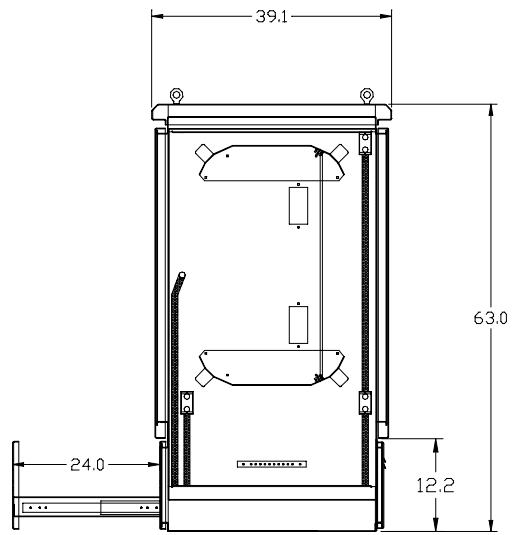

Fiber Storage Compartment

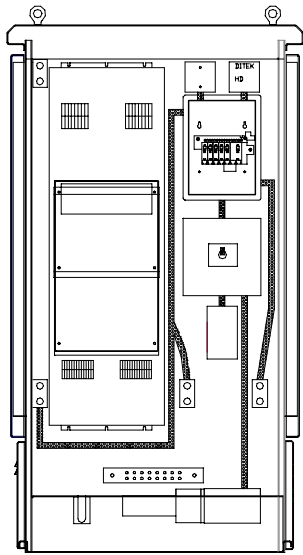

AC Distribution Compartment

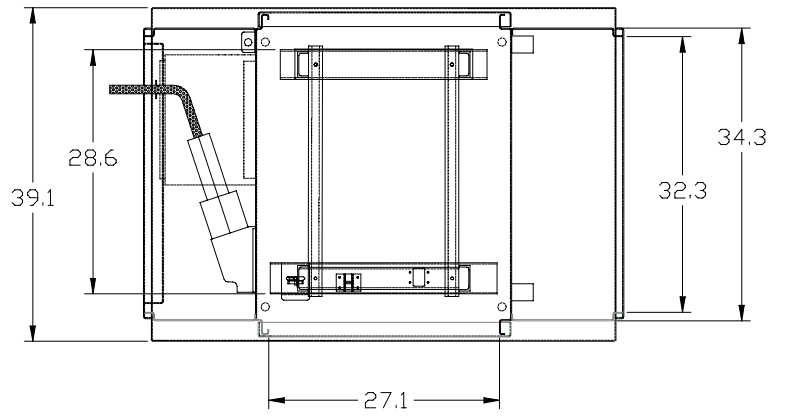

MCCES1 Top View

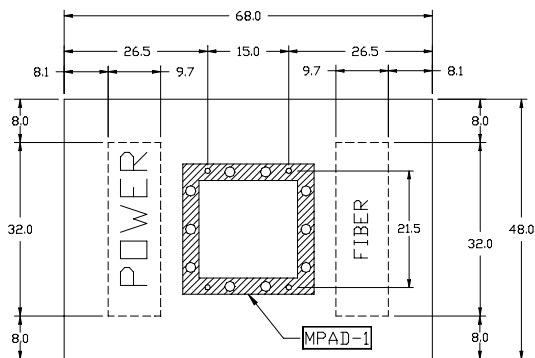

Pad Mounting Template with Frame

